

Contract Packager Series

Bringing high production and versatility together.

CP 1000

Front and Back or Round Product Labeling System delivers high production and versatility all in one system. The CP1000 features:

- Extra heavy-duty system framework with casters and leveling pads.
- Designed specifically for easy, rapid changeover.
- Two SL1500 digitally-controlled, stepper drive label applicators.
- NEMA 12 control enclosure with multi-level menu system.
- Synchronous overhead hold down.
- Synchronous product positioning.
- Automatic speed following and rate line compensation.



CP2000

Front and Back or Round High Speed Product Labeling System delivers high production and versatility all in one system. The CP2000 features:

- Extra heavy-duty system framework with casters and leveling pads.
- Designed specifically for easy, rapid changeover.
- Two high-speed SL2000 digitally-controlled, stepper drive label applicators.
- NEMA 12 control enclosure with multi-level menu system.
- Synchronous overhead hold down.
- Synchronous product positioning.
- Automatic speed following.

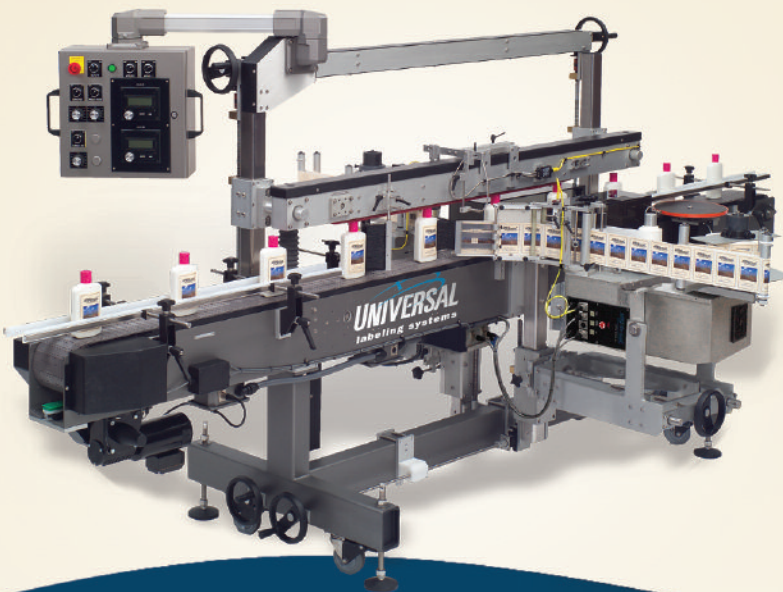

UNIVERSAL
labeling systems

Engineering
labeling solutions.

SPECIFICATIONS

CP1000

- 83.7" W x 144" L x 67.3" H
(Conveyor height to customer specifications with 4" total variance)
- Label dispense speed: 1500" per minute
- Label roll capacity: 12" Ø
- Web width: up to 6.375"
- Job save capacity: 99
- Electric: 120 VAC +/-10%
- Shipping weight: approx 1500 lbs.

Options

- Wide label capacity to 8.125"
- Hot stamp imprinter
- Feed and accumulating tables
- Low label detection

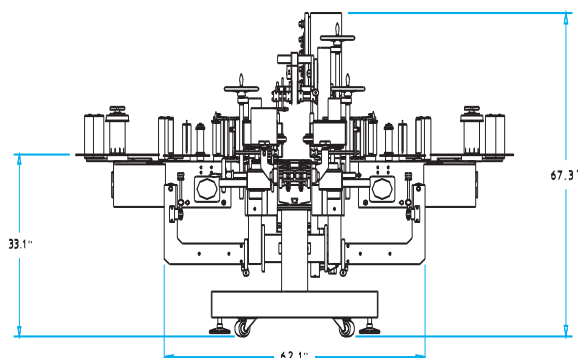
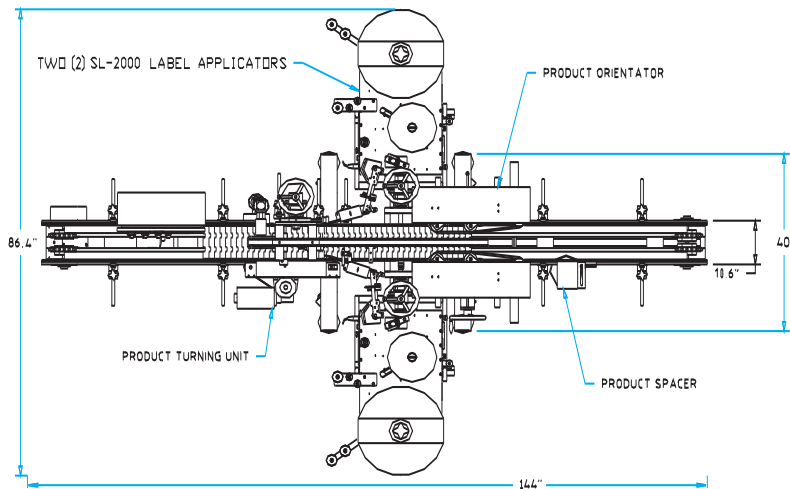
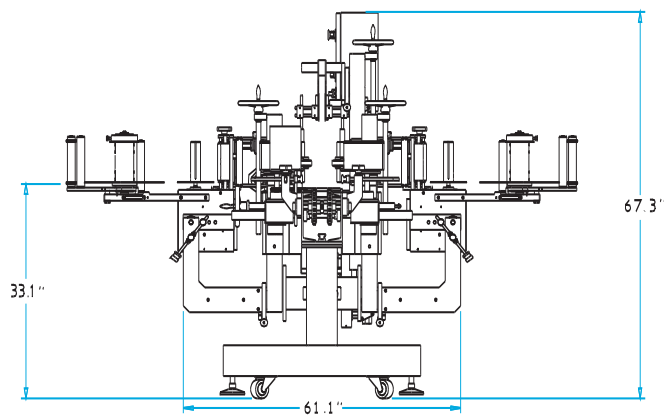
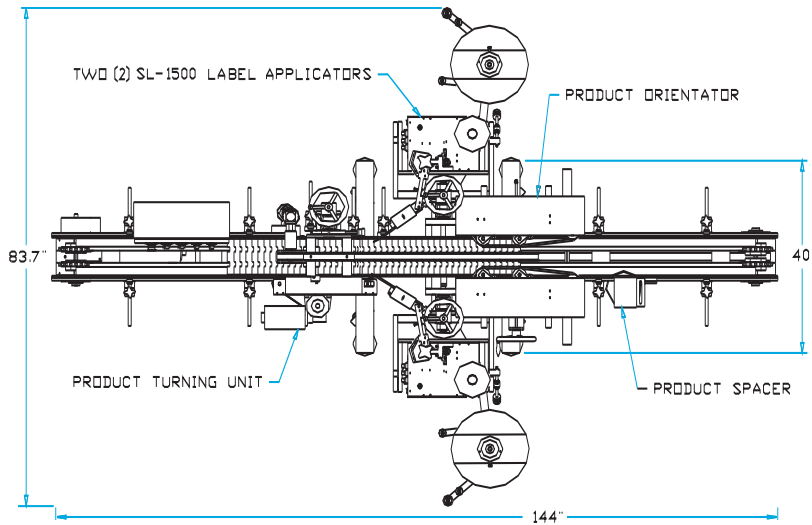

CP2000

- 86.4" W x 144" L x 67.3" H
(Conveyor height to customer specifications with 4" total variance)
- Label dispense speed: up to 3000" per minute
- Label roll capacity: 16" Ø
- Web width: up to 6.375"
- Electric: 120 VAC +/-10%
- Shipping weight: approx 1700 lbs.

Options

- Wide label capacity to 8.125"
- Hot stamp imprinter
- Feed and accumulating tables
- Low label detection

Universal Labeling Systems, Inc.

3501 8th Avenue South • St. Petersburg, FL 33711

1-877-236-0266 • sales@universal1.com

www.universal1.com