

# Automatic Round Product Labeling

*Cylindrical Solutions.*

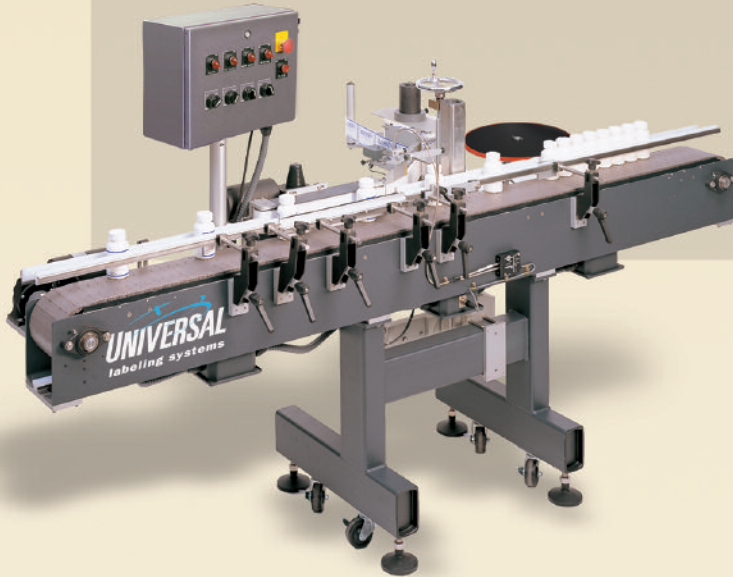

## R320

- Heavy-duty system framework
- L15H label applicator
- Variable speed components.
- Simple-to-use analog controls



## R321

- Heavy-duty system framework
- SL1500 label applicator
- Variable speed components
- Easy-to-use digital controls

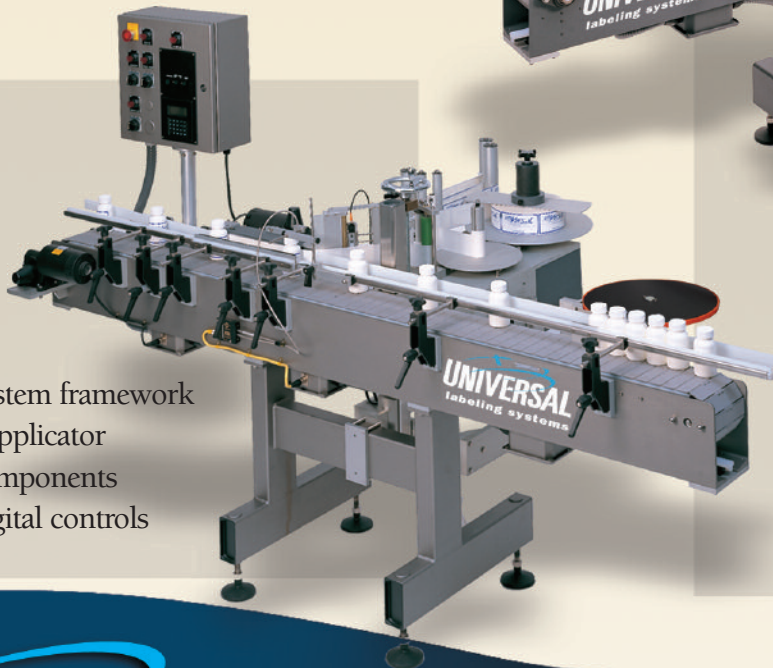

## R322

- Heavy-duty system framework
- SL2000 label applicator
- High-speed components
- Easy-to-use digital controls

**UNIVERSAL**  
labeling systems

Engineering  
labeling solutions.

# SPECIFICATIONS

## R320

- 51" W x 72" L x 56" H
- L15 Label Applicator
- Speed: up to 1200" per minute
- Label roll capacity: 12" Ø
- Web width: up to 6.5"
- Electric: 120 VAC +/-10%
- Shipping weight: approx. 1075 lbs.

### Options

- Hot stamp imprinter
- Spin 'n' Place with orientation
- Feed and accumulating tables
- Available in Stainless Steel

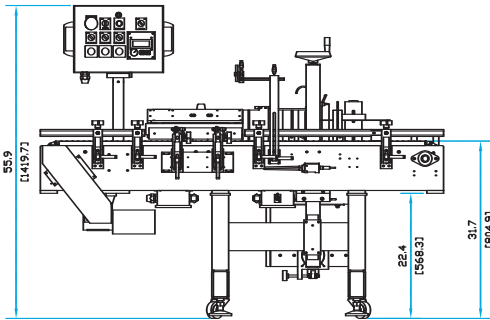
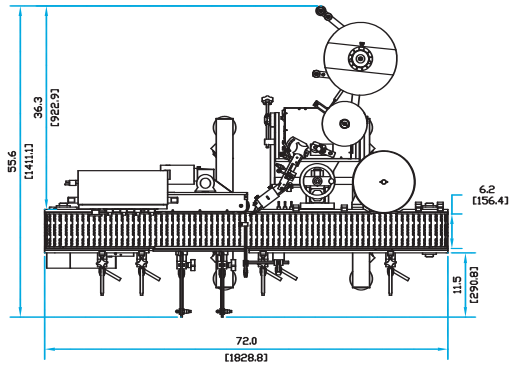
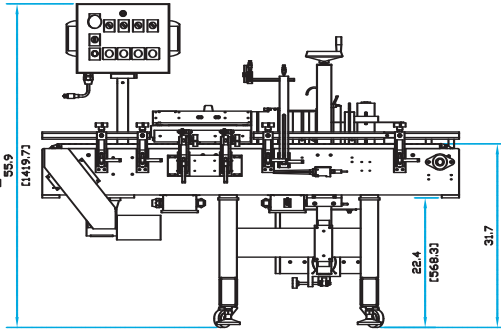
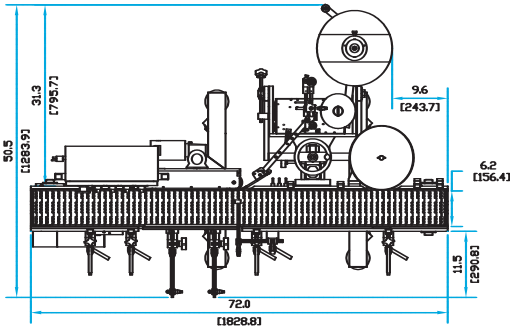

## R321

- 56" W x 72" L x 56" H
- SL1500 stepper driven label applicator
- Speed: up to 1,500" per minute
- Label roll capacity: 12" Ø
- Web width: up to 6.375"
- Electric: 120 VAC +/-10%
- Shipping weight: approx. 1100 lbs.

### Options

- Encoder with speed following
- Wide Web: up to 8.125"
- Hot stamp imprinter
- Spin 'n' Place with orientation
- Vacuumized wrap belt mechanism
- Feed & accumulating tables
- Available in Stainless Steel

## R322

- 59" W x 97" L x 64" H
- SL2000 stepper driven label applicator
- Speed: up to 3000" per minute
- Label roll capacity: 16" Ø
- Web width: up to 6.375"
- Electric: 120 VAC +/-10%
- Shipping weight: approx. 1160 lbs.

### Options

- Encoder with speed following
- Wide Web: up to 8.125"
- Hot stamp imprinter
- Spin 'n' Place with orientation
- Vacuumized wrap belt mechanism
- Vertical trunion mechanism
- Feed & accumulating tables
- Available in Stainless Steel

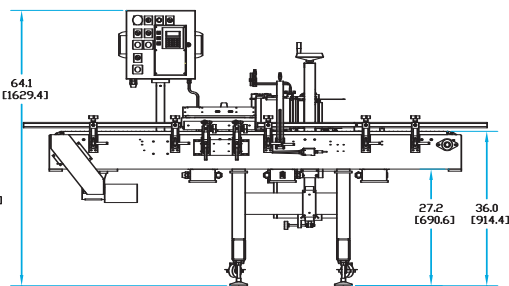
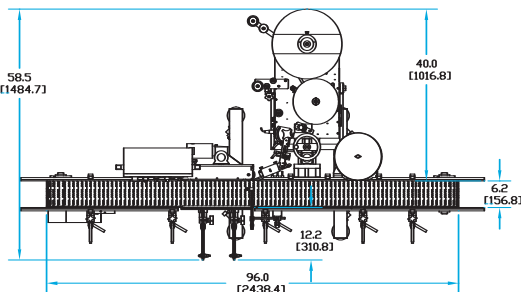

### Universal Labeling Systems, Inc.

3501 8th Avenue South • St. Petersburg, FL 33711

1-877-236-0266 • sales@universal1.com

www.universal1.com